

400_{VAC}

VN.MT40V

LARGE SECTIONAL DOORS, ROLLING DOORS AND UNBALANCED SHUTTERS INDUSTRIAL USE

manual chain override
quick release

BENINCA



100%
Made in Italy

400 Vac

- Irreversible electromechanical geared motor with manual chain movement and emergency release
- Ventilated electric motor ideal for intensive use and equipped with electric brake
- Two accessories are available for chain drives with reduction rates 1:1 (offset installation of motor) or 1:1.8 (torque or speed multiplier)
- Maximum safety guaranteed during rapid release phases, thanks to a micro-switch that cuts the power supply to the motor
- Oil lubricated reductions with hardened steel screw and bronze gears guarantee high performance, maximum reliability and silent operation
- 4 micrometrically adjustable limit switches



CONTROL UNITS:

VN.MT40V

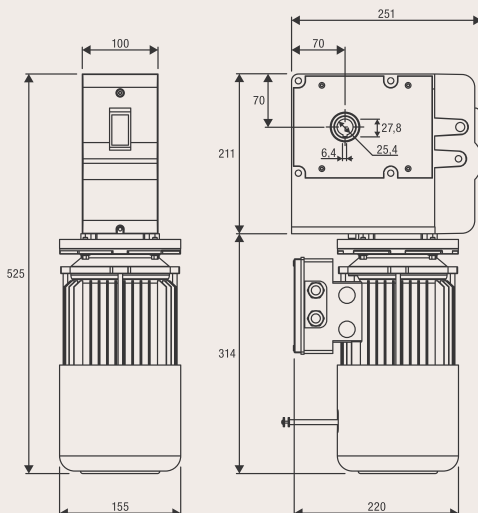
THINKY
START



VN.A30
Shaft adapter
Ø 30 mm.



VN.A3175
Shaft adapter
Ø 31.75 mm.



VN.A40
Shaft adapter
Ø 40 mm.



VN.RV
Transmission set
1:1.8 for 1" shaft
(25.4 mm) composed
of two gears with
external diameter
78 mm and 138.4 mm
and chain L = 1 m.



VN.RM
Transmission set 1:1
for 1" shaft (25.4 mm)
composed of two gears
with external diameter
78 mm and chain L = 1 m.

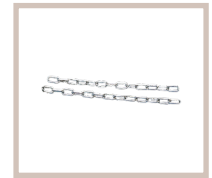

VN.CTA
Chain extension.

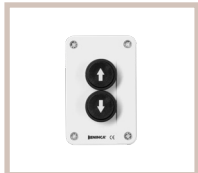

IPB.NO
Industrial keypad
fitted with 2 contacts
that are normally open.

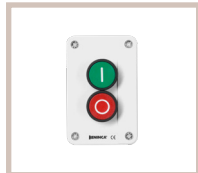

IPB.NC
Industrial keypad
fitted with a contact
that is normally open
and a contact
normally closed.



RF.SUN
Battery-operated device
recharged by means
of a photovoltaic panel
applied on a mobile edge.



RF
Device with a non
rechargeable battery,
with guaranteed
duration 2 years.



SC.RF
Device powered at
12/24 Vdc with self-test
function and 2 outputs
for connection to the
electronic control units.

AUTOMATISMI BENINCÀ SpA • Via del Capitello, 45 • 36066 Sandrigo (VI) ITALY • T +39 0444 751030 • sales@beninca.com

TECHNICAL DATA	VN.MT40V
Power supply	≈ 400 Vac (50-60Hz)
Motor supply	≈ 400 Vac
Max absorbed current	2.2 A
Max torque	340 Nm
Maximum output rotations	38
Output speed	24 r.p.m.
Shaft hole	1" (25.4 mm)
Limit switch red. rate	1/40
Duty cycle	intensive use
Protection level	IP40
Operating temperature	-20°C /+50°C
Lubrication	OIL
Weight	22.9 kg
Items no. per pallet	16